

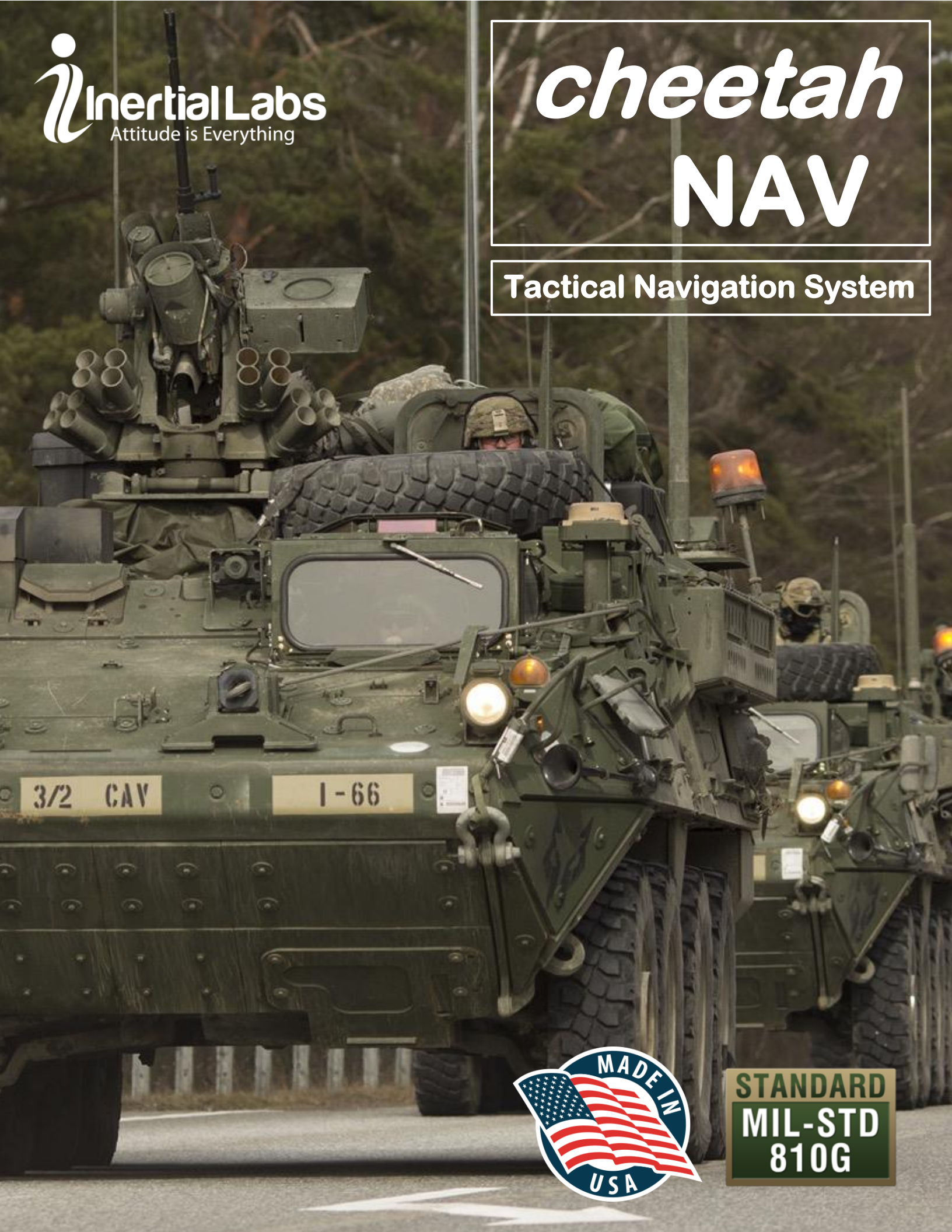

cheetah NAV

Tactical Navigation System



**STANDARD
MIL-STD
810G**

CheetahNAV is field-proven, PNT-capable high precision GNSS-Aided Inertial Navigation System (INS) which utilize tactical-grade, MEMS sensors based Inertial Measurement Unit (IMU); embedded, multi-constellation and multi frequency GNSS receiver; Advanced Kalman Filter based algorithm providing very accurate position information, navigation, time, velocity, and orientation in GNSS-enabled and GNSS-denied environments.

This versatile tactical navigation system which utilizes real-time moving map technology to provide the driver and crewmembers continuously with accurate situational awareness information. **CheetahNAV** has a user-friendly graphical navigation capability, combining inertial and satellite position information for accurately navigating between preset waypoints towards the destination. CheetahNAV makes use of an advanced Inertial Navigation System (INS), comprising several aids, including accelerometers and gyroscopes to provide accurate position, velocity, heading, pitch and roll of the platform using an advanced Kalman filter-based algorithm.



Ideal for tough battlefield conditions, the ruggedized **CheetahNAV** is designed and has been tested to withstand the most severe military environments. The CheetahNAV offers various options for vehicle installation, is vehicle agnostic, and is configurable to specific user needs, allowing flexibility as dictated by different mission requirements.

CheetahNAV is non-ITAR controlled and is the system of choice for land forces worldwide, meeting all their tactical navigation and battlefield management needs. A multi-language option ensures successful joint multinational operations.

KEY FEATURES, BENEFITS & FUNCTIONALITY

- ITAR-Free
- Route planning functionality
- Improved situational awareness
- Enhances mobility of vehicles
- Real time tactical moving map
- Multi language pack
- MIL-STD-2525B symbology
- Touch screen display
- Optional localization of production
- Ruggedized design
- Compact, MIL-STD qualified Inertial Navigation System (INS)
- Embedded GNSS receiver (uBlox / Novatel)
- Tactical-grade MEMS or FOG IMU
- Dead reckoning accuracy within 0.2% of distance traveled (DT)
- Technology Readiness Level (TRL 9)
- Affordable price

The crew of the vehicle is provided with the following guidance queues to execute the planned tactical maneuvers:

- Current Vehicle Speed and True Heading of the vehicle
- Current Vehicle Position
- Desired Heading towards the Next Waypoint or Destination
- Desired Vehicle Speed to reach the Next Waypoint or Destination at the planned time
- Next Waypoint or Destination Position and Distance to the Next Waypoint
- Pitch and Roll Attitude of the vehicle
- Track traveled by the vehicle

The vehicle navigation system is a 'map based' navigation system that will allow maximum tactical advantage by enhancing the situational awareness of the crew at a reasonable cost. The system uses an Inertial Measurement Unit, combined with a GNSS to allow dead reckoning and positional accuracies, to allow the vehicle to fulfill its role in a tactical offensive.

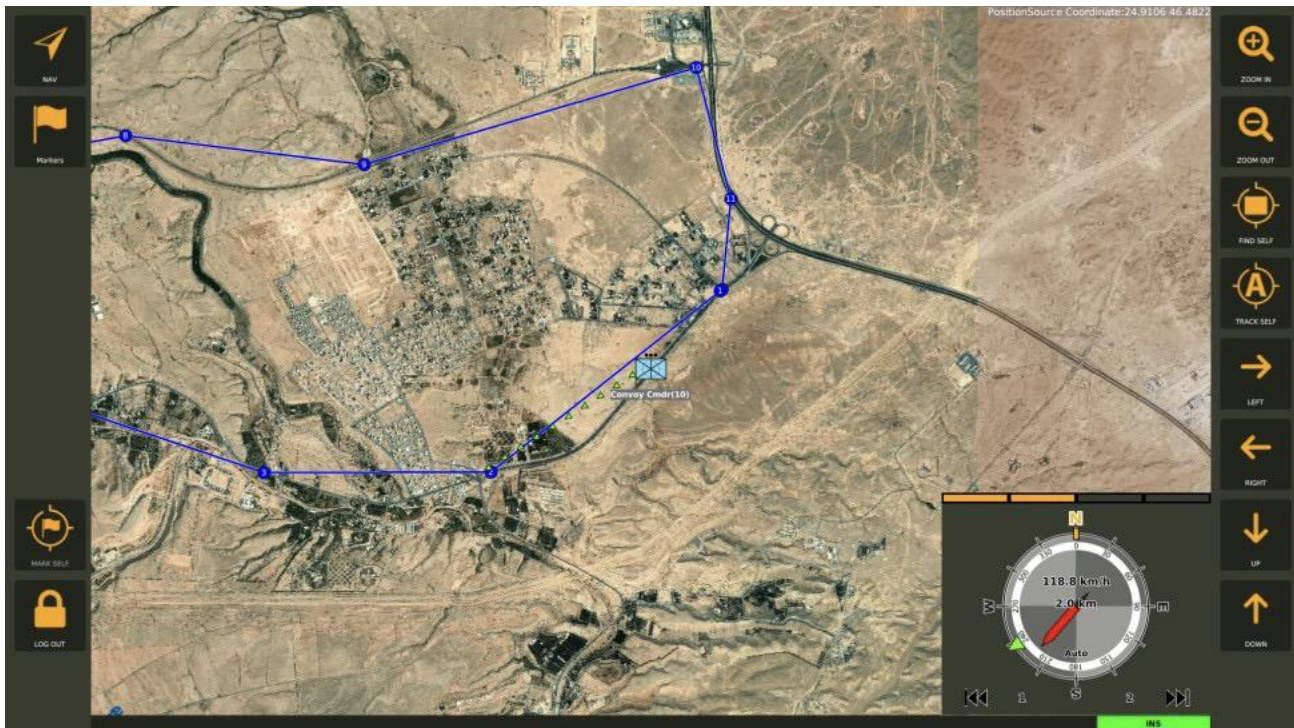

Optional Features

- Battle management system integration
- Multifunctional HD display sharing for other vehicle systems
- Freeform messaging Anti GNSS spoofing and jamming
- Additional displays
- External IP Video or SDI Video input processing

Specifications

MAIN DISPLAY UNIT

Display

- 11.6" Diagonal 16:9TFT
- 1920 x 1080 Resolution
- Sunlight Readable
- Resistive touch
- Weight: 4050 grams

Interfaces

- Ethernet (GbE)
- 28 VD C (MIL-STD-1275E)
- RS-422/USB/CAN
- GPS Antenna interface
- IMU/INS interface
- Wheel sensor/Odometer interface
- Optional SDI or IP video interface

DRIVER DISPLAY UNIT

Display

- 3.5" Diagonal TFT
- 240 x 320 Resolution
- Sunlight Readable
- Weight: 650 grams

Interfaces

- Serial RS422
- Ethernet (PoE)
- Optional touch screen interface

Inertial Navigation	
Heading Accuracy (Static)	1.0° RMS (INS-B) / 0.08° RMS (INS-D)
Heading Accuracy (Dynamic, GNSS)	0.2° RMS (INS-B) / 0.08° RMS (INS-D)
Heading Accuracy (Gyro compassing) ⁽¹⁾	<0.16° RMS * sec Lat
Pitch/Roll Accuracy (Static)	0.06° RMS
Pitch/Roll Accuracy (Dynamic, w/GNSS)	0.03° RMS
Horizontal Position Accuracy (with GNSS)	1.8 m RMS
Horizontal Position Accuracy (GNSS-denied, free inertial, RMS) ⁽²⁾	0.2% of distance traveled (DT)
Vertical Position Accuracy	1.8 m RMS
Velocity Accuracy	± 0.05 m/s RMS (uBlox); ± 0.03 m/s RMS (Novatel)
Angular Resolution	< 0.04° RMS
Output Rate (IMU Data)	2000 Hz
Output Rate (INS Data)	200 Hz

⁽¹⁾ optional using INS with FOG IMU; ⁽²⁾ after INS filter convergence

GNSS options				
GNSS	Units	NovAtel OEM719	NovAtel OEM7720	uBlox ZED-F/D9P
GNSS Antennas	-	Single	Dual	Single or Dual
GNSS Constellations	-	GPS L1/L2/L5; GLONASS L1/L2/L3/L5; BeiDou B1/B2/B3; Galileo E1/E5/E6; NavIC (IRNSS) L5; QZSS L1/L2/L5/L6; L-Band	GPS L1/L2/L5; GLONASS L1/L2/L3/L5; BeiDou B1I, B1C, B2I, B2a, B3I; Galileo E1/E5/E6; NavIC (IRNSS) L5; QZSS L1 QZSS L1/L2/L5; L-Band	GPS L1/L2, GLONASS L1/L2, Galileo E1/E5, BeiDou B1/B2, QZSS L1/L2
GNSS Corrections	-	WAAS; EGNOS; MSAS; GAGAN; SBAS; DGPS; RTK; PPP Terrastar	WAAS; EGNOS; MSAS; GAGAN; SBAS; DGPS; RTK; PPP Terrastar	WAAS; EGNOS; MSAS; GAGAN; DGPS; RTK
GNSS Channels	-	555	555	184
GNSS Data Rate	Hz	5 / 20 / 100	5 / 20 / 100	10, 20
RTK Corrections	-	RTCM 2, RTCM 3	RTCM 2, RTCM 3	RTCM 3
Velocity Accuracy	m/s	0.03	0.03	0.05
Initialization Time	s	<39 (cold start), <20 (hot start)	<39 (cold start), <20 (hot start)	<30 (cold start), <10 (hot start)
Time (clock drift)	n sec	20	20	30

Tactical-grade IMU	Accelerometers	Gyroscopes	Barometer
Range	± 15 g	± 450°/s	300-1100 hPA
In-Run Bias Stability	< 0.02 mg	< 1°/hr	2 Pa
Noise Density	0.035 m/s/√hr	0.2°/√hr	0.8 Pa/√Hz

Environmental	
Temperature (Operational)	-20°C to +71°C
Temperature (Storage)	-40°C to +80°C
Vibration	MIL-STD810G 'Operational Service' as for Category 20 Ground Vehicles. MIL-STD810G 'Transportation' as for Category 6 Large Assembly Cargo.
Shock	MIL-STD810G 'Procedure I – Functional Shock' of 40g as for Ground Equipment.
Humidity	MIL-STD810G Procedure I – Natural' of 80%RH at 40°C.
Sand and Dust	MIL-STD810G Dust (<150um) Procedure' as for Ground Vehicles.
Electromagnetic Compatibility	MIL-STD-461F Class B.
Altitude	MIL-STD810G 'Procedure I – Storage/Air Transport' up to 15km (50,000 feet).
Input Voltage	28V DC MIL-STD-1275E
MTBF	15,000 hours @55°C Ground Mobile

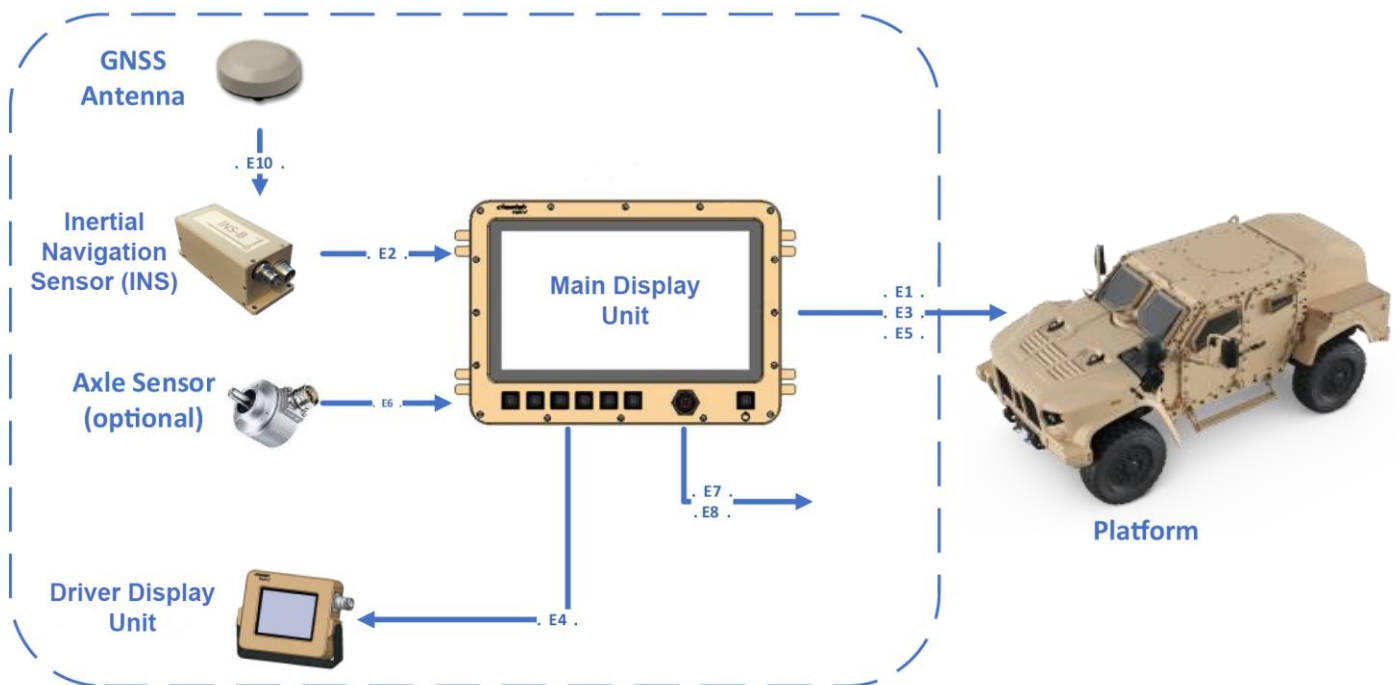

Main Display Unit



Driver Display Unit

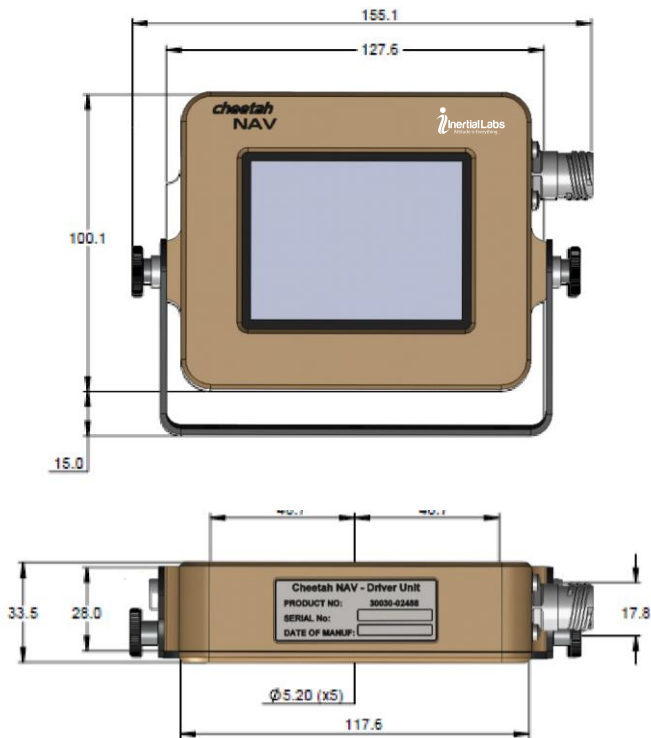

Inertial Navigation System INS-B

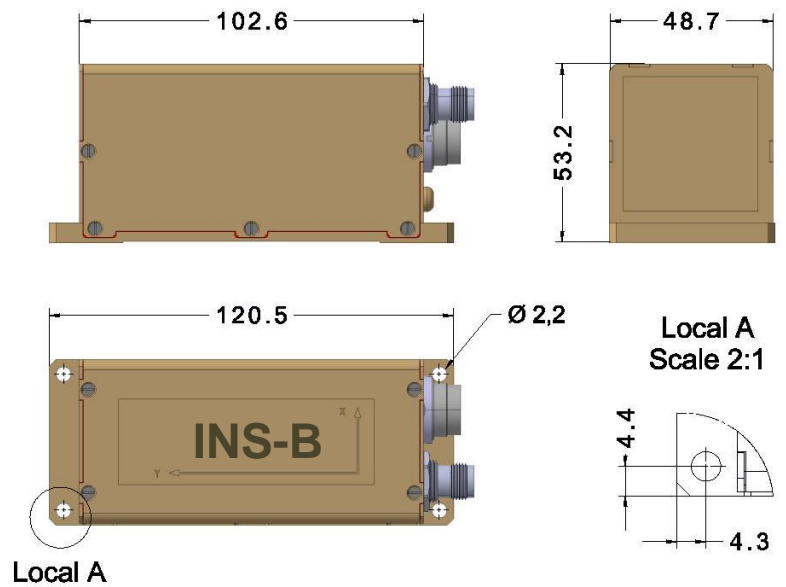

All dimensions are in mm.