



GPS-Aided Inertial Navigation System

INS-DM



The **Inertial Labs GPS-Aided Inertial Navigation System (INS-DM)** is the latest version of Inertial Navigation System, developed by Inertial Labs. The INS-DM is the result of over 20 years of our experience in developing and supplying INS solutions to land, marine and aerial platforms around the world.

This system, the INS-DM, is an IP68 rated version of an all-new generation of super ruggedized, shielded from the EMC/EMI, fully-integrated, combined Inertial Navigation System (INS) + Attitude & Heading Reference System (AHRS) + Air Data Computer (ADC) high-performance strapdown system, that determines position, velocity and absolute orientation (Heading, Pitch and Roll) for any device on which it is mounted. Horizontal and Vertical Position, Velocity and Orientation are determined with high accuracy for both motionless and dynamic applications.



The Inertial Labs **INS-DM** can support multiple types of MEMS Inertial Measurement Units (IMU) developed by Inertial Labs. Additionally, the **INS-DM** supports other IMU's, like the Honeywell HG4930. The **INS-DM** also utilizes different multi constellation (GPS, GLONASS, GALILEO, QZSS and BEIDOU) GNSS receivers like NovAtel OEM7 series or the u-blox F9 series.

The design of the **INS-DM** also includes an optional Air Data Computer (ADC), supported by two barometers, and the ability to support an external Stand-Alone Magnetic Compass (SAMC). The **INS-DM** contains Inertial Labs new on-board sensor fusion filter, state of the art navigation and guidance algorithms, and calibration software.

KEY FEATURES, BENEFITS & FUNCTIONALITY

- Commercially exportable GPS-Aided Inertial Navigation System
- 3-in-1 strapdown system: INS + AHRS + ADC (Air Data Computer)
- Embedded Honeywell or Inertial Labs MEMS Inertial Measurement Unit (IMU)
- NovAtel OEM7, u-blox ZED-F9P, or Septentrio mosaic-H High Precision GNSS receiver
- GPS, GLONASS, GALILEO, BEIDOU, QZSS, RTK supported signals
- Total and Static Pressure Sensors for calculating Indicated Airspeed
- SP, SBAS, DGPS, RTK and PPP for real time operation
- GNSS measurements and IMU raw data for post processing
- Advanced, extendable, embedded Kalman Filter based sensor fusion algorithms
- State-of-the-art algorithms for different dynamic motions of Helicopters, and UAV
- Full temperature calibration of all sensing elements
- EMC, EMI, and ERD protection
- Environmentally sealed (IP68)
- Aiding data: Wind sensor, Air Speed Sensor, Doppler shift from locator (for long-term GPS denied), External position and External Heading

General

Optional Input Signals	
<ul style="list-style-type: none"> External Magnetometer, Wind sensor, Air Speed Sensor, Doppler shift from locator (for long-term GPS denied), External position and External Heading aiding data 	
Output Signals	
<ul style="list-style-type: none"> IMU data: Accelerations, Angular rates, Magnetic field; AHRS data: Heading, Pitch & Roll INS data: Positions, Velocity, Delta Theta and Delta Velocity, GNSS data, Time Air Data Computer data: Static Pressure (calibrated), Dynamic Pressure (calibrated), Baro-Corrected Pressure Altitude, Pressure Altitude, Calibrated Airspeed, True Airspeed, Mach-Number, Static Pressure Over Total Pressure, True Angle of Attack, Rate of Climb 	
Electrical & Mechanical	
Update rate	1 ... 200 Hz (INS & AHRS data); up to 2000 Hz (IMU data)
Start-up time	<1 sec
Interface	RS-232 / RS-422 / CAN / Ethernet
Input power protection	MIL-STD-1275 (optional)
Input power	9 to 36 V DC (27 ± 10 for MIL-STD-1275 protection)
Output data	Binary, NMEA 0183 ASCII characters
1 PPS level	3.3 V DC TTL / 5 V DC TTL / differential
EMC/EMI	MIL-STD-461F
Type of Sealing	IP68
MTBF	100000 hours
Dimensions	160.4 x 141.2 x 61.1 mm
Weight	1345 grams (depends on configuration)
Environment	
Operational Temperature	-40 to +80C
Storage Temperature	-50 to +85C
Humidity	Up to 95%
Sand, Dust, Water, Shock, Vibration	MIL-STD-810G
Altitude	up to 15,000 m (50,000 ft)
Acoustic noise	185 dB max

IMU Options



miniAHRS



KERNEL-110



KERNEL-210



IMU-NAV-100



HG4930 CA51

GYROSCOPES

	miniAHRS	KERNEL-110	KERNEL-210	IMU-NAV-100	HG4930 CA51
Measurement range	±2000 deg/sec	±2000 deg/sec	±2000 deg/sec	±2000 deg/sec	±400 deg/sec
Bias in-run stability, RMS	2 deg/hr	2 deg/hr	1 deg/hr	0.5 deg/hr	0.25 deg/hr
Bias residual error, RMS	72 deg/hr	72 deg/hr	25 deg/hr	15 deg/hr	7 deg/hr
SF error	1000 ppm	1000 ppm	1000 ppm	1000 ppm	100 ppm
Noise (ARW)	0.38 deg/√hr	0.38 deg/√hr	0.2 deg/√hr	0.1 deg/√hr	0.04 deg/√hr

ACCELEROMETERS

	miniAHRS	KERNEL-110	KERNEL-210	IMU-NAV-100	HG4930 CA51
Measurement range	±8g (±15g & ±40g)	±8g (±15g & ±40g)	±8g (±15g & ±40g)	±8g (±15g & ±40g)	±20g
Bias in-run stability, RMS	0.01 mg	0.01 mg	0.005 mg	0.003 mg	0.025 mg
Bias residual error, RMS	0.7 mg	0.7 mg	0.5 mg	0.4 mg	1.7 mg
SF error	500 ppm	500 ppm	150 ppm	150 ppm	600 ppm
Noise (VRW)	0.02 m/s/√hr	0.02 m/s/√hr	0.015 m/s/√hr	0.008 m/s/√hr	0.03 m/s/√hr

Magnetometer

	INS-DM-M1	INS-DM-E1	INS-DM-A1	INS-DM-N11	INS-DM-B1
Measurement range (Gauss)	±8.0	-	±1.6	±1.6	±1.6
Bias in-run stability, RMS (µGauss, 1σ)	8	-	0.2	0.2	0.2
Noise density, PSD (µGauss /√Hz, 1σ)	15	-	3	3	3
SF accuracy (ppm, 1σ)	500	-	50	50	50

GNSS Receiver Options



NovAtel OEM7720



u-blox ZED-F9P



Septentrio mosaic-H

Specifications			
Number of GNSS Antennas	Dual	Dual	Dual
GNSS constellations	GPS L1 C/A, L1C, L2C, L2P, L5; GLONASS L1 C/A, L2 C/A, L2P, L3, L5; BeiDou B1I, B1C, B2I, B2a, B3I; Galileo E1, E5 AltBOC, E5a, E5b, E6; NavIC (IRNSS) L5; QZSS L1 C/A, L1C, L2C, L5, L6; L-Band	GPS L1C/A L2C, GLONASS L1OF L2OF, Galileo E1B/C E5b, BeiDou B1I B2I, QZSS L1C/A L2C	GPS L1C/A, L1C, L1PY, L2C, L2P, L5; GLONASS L1CA, L2CA, L2P, L3 CDMA; Beidou B1I, B1C, B2a, B2I, B3; Galileo E1, E5a, E5b, E5 AltBoc, E6; QZSS L1C/A, L1C, L2C, L5, L6; Navic L5; L-band
GNSS corrections	WAAS; EGNOS; MSAS; GAGAN; SBAS L1, L5; DGPS; RTK; PPP Terrastar	WAAS; EGNOS; MSAS; GAGAN; SBAS L1C/A; DGPS; RTK	WAAS; EGNOS; MSAS; GAGAN; SBAS L1, L5; DGPS; RTK
Channel configuration ⁽¹⁾	555 Channels	184 Channels	448 Channels
GNSS data rate ⁽¹⁾	5 Hz / 20 Hz / 100 Hz	10, 20 Hz ⁽²⁾	100 Hz (max)
RTK corrections	RTCM 2, RTCM 3	RTCM 3	RTCM 2, RTCM 3
Velocity accuracy, RMS	0.03 m/sec	0.05 m/sec	0.03 m/sec
Initialization time	<39 (cold start), <20 (hot start)	<30 (cold start) <10 (hot start)	<45 (cold start) <20 (hot start)
Time accuracy (clock drift) ⁽³⁾	20 nano sec	30 nano sec	20 nano sec

⁽¹⁾ tracks up to 60 L1/L2 satellites; ⁽²⁾ If tracking GPS Only; ⁽³⁾ time accuracy does not include biases due to RF or antenna delay

Air Data Computer



Honeywell



Honeywell

Specifications	Using Honeywell 025MD sensor	Using Honeywell 600MD sensor
Static Pressure (calibrated)	300 to 1100 hPa, from -2000 ft to 30000 ft, Accuracy: ±0.1% FSS	300 to 1100 hPa, from -2000 ft to 30000 ft, Accuracy: ±0.1% FSS
Dynamic Pressure (calibrated)	0.15 to 25 hPa / 10 to 124 KCAS, Accuracy: ±0.25% FSS	0.15 to 600 hPa / 10 to 600 KCAS, Accuracy: ±0.25% FSS
Baro-Corrected Pressure Altitude	-500 to 9000 meters; Accuracy: 1	-500 to 9000 meters; Accuracy: 1
Pressure Altitude	-500 to 9000 meters; Accuracy: 1	-500 to 9000 meters; Accuracy: 1
Calibrated Airspeed	5 to 64 meters/sec; Accuracy: 0.5	5 to 310 meters/sec; Accuracy: 0.5
True Airspeed	5 to 64 meters/sec; Accuracy: 0.5	5 to 310 meters/sec; Accuracy: 0.5
Mach-Number	0.01 to 0.2 M, Accuracy: 0.001 M	0.01 to 0.99 M, Accuracy: 0.002 M
Static Pressure Over Total Pressure	0.97 to 1, Resolution 0.000001	0.63 to 1, Resolution 0.000001

True Angle of Attack	-50 to 50 deg; Accuracy ± 0.25		-50 to 50 deg, Accuracy ± 0.25		
Rate of Climb	± 515 meters/sec; Accuracy 0.05		± 515 meters/sec; Accuracy 0.05		
Air Density	0.3 to 1.6 kg/m ³ ; Accuracy 0.002		0.3 to 1.6 kg/m ³ ; Accuracy 0.002		
Outside Air Temperature (OAT)	-40 to +85 deg C; Resolution 0.01		-40 to +85 degC; Resolution 0.01		
Wind Speed	± 200 meters/sec; Accuracy: 0.1		± 200 meters/sec; Accuracy: 0.1		
INS Options					
	Model:	INS-DM-M1	INS-DM-E1	INS-DM-A1	INS-DM-N11
Weight (grams):	1,060	1,047	1,110	1,255	1,300
TYPE of IMU:	IMU: miniAHR5	IMU: KERNEL-110	IMU: KERNEL-210	IMU: IMU-NAV-100	IMU: HG4930 CA51
NAVIGATION					
Horizontal position accuracy (SP)	1.2 m	1.2 m	1.2 m	1.2 m	1.2 m
Horizontal position accuracy (SBAS) ⁽¹⁾	0.6 m	0.6 m	0.6 m	0.6 m	0.6 m
Horizontal position accuracy (DGPS)	0.4 m	0.4 m	0.4 m	0.4 m	0.4 m
Horizontal position accuracy (PPP TerraStar-C PRO) ⁽²⁾	0.025 m	0.025 m	0.025 m	0.025 m	0.025 m
Horizontal position accuracy (PPK) ⁽³⁾	0.005 m	0.005 m	0.005 m	0.005 m	0.005 m
Horizontal position accuracy (RTK)	0.01 m	0.01 m	0.01 m	0.01 m	0.01 m
Vertical position accuracy (RTK)	0.02 m	0.02 m	0.02 m	0.02 m	0.02 m
Velocity accuracy (OEM7720), RMS	0.03 m/sec	0.03 m/sec	0.03 m/sec	0.03 m/sec	0.03 m/sec
Velocity accuracy (u-blox F9P), RMS	0.05 m/sec	0.05 m/sec	0.05 m/sec	0.05 m/sec	0.05 m/sec
Horizontal Position accuracy (free inertial, land vehicles)	1% DT	1% DT	0.2% DT	0.1% DT	0.1% DT
Horizontal Position accuracy (free inertial, aerial)	<10 NMPH	<10 NMPH	<7 NMPH	<5 NMPH	<3 NMPH
HEADING					
Range	0 to 360 deg	0 to 360 deg	0 to 360 deg	0 to 360 deg	0 to 360 deg
Angular Resolution	0.01 deg	0.01 deg	0.01 deg	0.01 deg	0.01 deg
Static & Dynamic Accuracy ⁽⁴⁾ (Dual antenna, 1 meter baseline)	0.15 deg	0.15 deg	0.15 deg	0.15 deg	0.15 deg
Static & Dynamic Accuracy ⁽⁴⁾ (Dual antenna, 2 meters baseline)	0.08 deg	0.08 deg	0.08 deg	0.08 deg	0.08 deg
Dynamic Accuracy ⁽⁴⁾ (Single antenna)	0.15 deg	0.15 deg	0.15 deg	0.15 deg	0.15 deg
Post processing accuracy ⁽³⁾	0.05 deg	0.05 deg	0.03 deg	0.015 deg	0.01 deg
Free inertial	10 deg/hr	10 deg/hr	2 deg/hr	1 deg/hr	0.5 deg/hr
PITCH & ROLL					
Range	$\pm 90, \pm 180$	$\pm 90, \pm 180$	$\pm 90, \pm 180$	$\pm 90, \pm 180$	$\pm 90, \pm 180$
Angular Resolution	0.01	0.01	0.01	0.01	0.01
Static Accuracy	0.08	0.08	0.05	0.03	0.02
Dynamic Accuracy (with GNSS correction)	0.05	0.05	0.03	0.02	0.01
Post processing accuracy ⁽³⁾	0.05 deg	0.05 deg	0.006 deg	0.003 deg	0.002 deg

⁽¹⁾ GPS only; ⁽²⁾ For NovAtel OEM7720 GNSS receiver only. Requires a subscription to a TerraStar data service; ⁽³⁾ RMS, incremental error growth from steady state accuracy. Post-processing results using third party software; ⁽⁴⁾ dynamic accuracy may depend on type of motion;

Product Code Structure

Model	IMU type	Gyro	Acc	Calibration	Connector	Encoder support	Pressure Ports	Color	External Compass	Data Logger	GNSS receiver	Version	Interface
INS-DM	M1	G2000	A8	TGA	C71	E	0P	B	SAMC	S64	ZD9P	VD9	12345
	E1	G950	A15	TMGA	C72		2P	G			O7720		1245
	A1	G450	A20		C73		2PEXT	D			DMH		145
	N11	G400	A40										
	B1												

Example: INS-DM-E1-G2000-A8-TGA-C71E-2P-B-SAMC-S64-ZD9P-VD9.12345

Product code details:

- INS-DM: Dual Antenna GPS-Aided Inertial Navigation System
- M1: Inertial Labs miniAHRS Attitude & Heading Reference System
- E1: Inertial Labs KERNEL-110 IMU
- A1: Inertial Labs KERNEL-210IMU
- N11: Inertial Labs IMU-NAV-100
- B1: Honeywell HG4930 CA51 IMU
- G2000: Gyroscopes measurement range = ± 2000 deg/sec
- G950: Gyroscopes measurement range = ± 950 deg/sec
- G450: Gyroscopes measurement range = ± 450 deg/sec
- G400: Gyroscopes measurement range = ± 400 deg/sec (using Honeywell HG4930 CA51 IMU)
- A8: Accelerometers measurement range ± 8 g
- A15: Accelerometers measurement range ± 15 g
- A20: Accelerometers measurement range ± 20 g (using Honeywell HG4930 CA51 IMU)
- A40: Accelerometers measurement range ± 40 g
- TGA: Calibration of IMU (Gyroscopes and Accelerometers) in operational temperature range
- TMGA: Calibration of IMU (Magnetometers, Gyroscopes and Accelerometers) in operational temperature range
- C71: two connectors (22 – main; 13 – auxiliary)
- C72: C71 with MIL-STD-1275 protection
- C73: MIL-STD-1275 protection, enclosure with asymmetrical alignment mounting holes
- E: Encoder support
- 0P: Zero Airspeed Pressure Ports (Total/Static)
- 2P: Two Airspeed Pressure Ports with Standard Range (Total/Static, Honeywell 025MD)
- 2PEXT: Two Airspeed Pressure Ports with Extended Range (Total/Static, Honeywell 600MD)
- B: Black Color of enclosure (default)
- G: Green Color of enclosure (optional)
- D: Desert Tan Color of enclosure (optional)
- SAMC: External Stand-Alone Magnetic Compass (optional)
- S64: 64GB embedded Data Logger (optional)
- ZD9P: u-blox ZED-F9P dual antenna GNSS receiver
- O7720: NovAtel OEM7720 dual antenna GNSS receiver
- DMH: Septentrio mosaic-H dual antenna GNSS receiver
- VD9: GPS L1/L2, GLONASS L1/L2, BEIDOU B1/B2, GALILEO E1/E5, QZSS L1/L5, DGPS, RTK, Dual antenna Heading, GNSS measurements, GNSS positions (Dual Antenna GNSS Receiver only)
- .12345: RS-232, RS-422, RS-485 (for stand-alone magnetic compass only), CAN, Ethernet
- .1245: RS-232, RS-422, CAN, Ethernet (in case of using internal datalogger)
- .145: RS-232, CAN, Ethernet (in case of using internal datalogger + encoder)

Mechanical and Electrical Interfaces Description

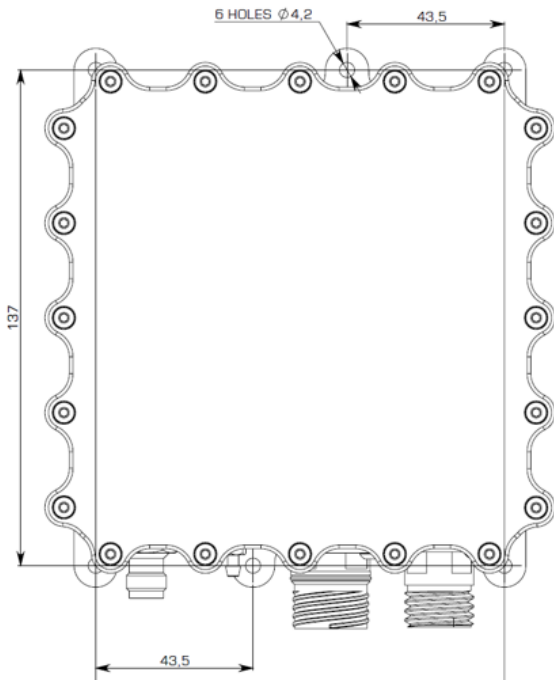
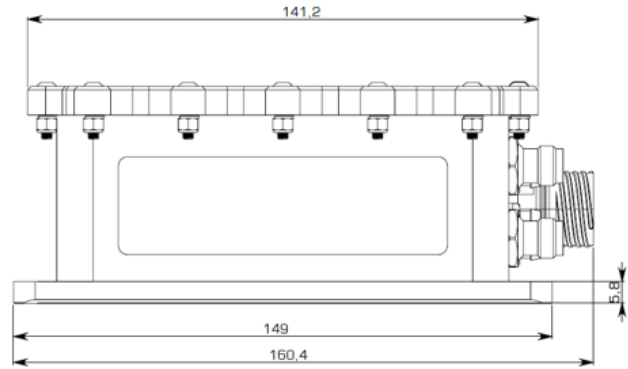
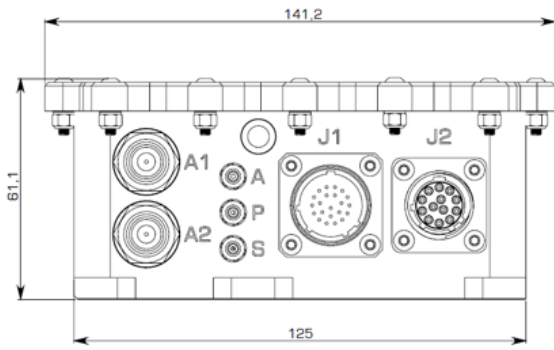

J1 - D38999/20WC35PN - 22 PINS

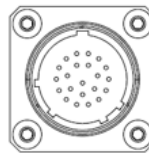

POWER INPUT	1
POWER RETURN	2
RS232-RX1	3
RS232-TX1	4
RS232-RX2	5
RS232-TX2	6
RS232-RX3	7
RS232-TX3	8
RX4/CAN1-LOW	9
TX4/CAN1-HIGH	10
COMMON GND	11

RS422-RX1+	12
RS422-RX1 -	13
RS422-TX1+	14
RS422-TX1 -	15
1PPS OUT	16
MARK INPUT	17
ETHERNET TX+	18
ETHERNET TX -	19
ETHERNET RX+	20
ETHERNET RX -	21
COMMON GND	22

J2- D38999/20WB35PN - 13 PINS

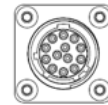

5V OUTPUT	1
COMMON GND	2
ENC. PHASE A	3
ENC. PHASE B	4
RS485-A	5
RS485-B	6
RESERVED	7
RESERVED	8
AUX. RS232-TX4	9
AUX. RS232-RX4	10
CAN2 HIGH	11
CAN2 LOW	12
COMMON GND	13

Notes:

1. All dimensions are in millimeters
2. All pinouts and dimensions are subject to change without notice. For verification of validity of mechanical drawing please contact Inertial Labs Support.

