



# Dual Antenna, GPS-Aided Inertial Navigation Systems INS-DU-OEM



**INS-DU-OEM Specifications**

Parameter	Units	INS-DU-OEM			
<b>General</b>	Input signals	<ul style="list-style-type: none"> <li>Marine application: DVL (Doppler Velocity Log)</li> <li>Land application: Odometer, Wheel sensor, Encoder, DMI</li> <li>Aerial application: Wind sensor, Air Speed Sensor, Doppler shift from locator (for long-term GPS denied)</li> <li>All: External Stand-Alone Magnetic Compass (SAMC/AHRS)</li> </ul>			
	Output signals	<ul style="list-style-type: none"> <li>Horizontal and Vertical Positions, Heading, Pitch &amp; Roll, Velocity, Accelerations, Angular rates, Barometric data, PPS</li> <li>Direct AT_ITINS message with Position, Heading, Pitch &amp; Roll to COBHAM AVIATOR UAV 200</li> </ul>			
	Main features	Low Cost, Dual antenna Heading, 1 cm RTK position			
	Data rate (INS)	Hz	Up to 200 (user settable)		
	Data rate (IMU)	Hz	Up to 2000 (user settable)		
Start-up time	sec	<1			
<b>Positions, Velocity and Timestamps</b>		<b>Units</b>	<b>INS-DU-OEM</b>		
<b>Navigation</b>	Horizontal position accuracy (SP, L1), RMS	meters	1.5		
	Horizontal position accuracy (SP, L1/L2), RMS	meters	1.2		
	Horizontal position accuracy (post processing) <sup>(1)</sup>	meters	0.005		
	Horizontal position accuracy (RTK), RMS	meters	0.01 + 1 ppm CEP		
	Vertical position accuracy (SP), RMS	meters	<2		
	Vertical position accuracy (RTK), RMS	meters	0.02 + 1 ppm CEP		
	Position Accuracy (Free Inertial Land Vehicle) <sup>(2)</sup>	% DT	1 (Tunnel Guide positional aiding references)		
	Velocity accuracy, RMS	meters/sec	0.05		
PPS timestamps accuracy	nano sec	20			
<b>Heading</b>		<b>Units</b>	<b>INS-DU-OEM</b>		
<b>Orientation</b>	Range	deg	0 to 360		
	Static / Dynamic Accuracy (INS with Septentrio mosaic-H receiver) <sup>(3)(4)</sup>	deg RMS, 1σ	0.08 (2m baseline); 0.15 (1m baseline)		
	Static / Dynamic Accuracy (INS with u-blox ZD9P receiver) <sup>(3)(4)</sup>	deg RMS, 1σ	0.2 (2m baseline); 0.4 (1m baseline)		
	Post processing accuracy (INS with Septentrio mosaic-H receiver) <sup>(1)</sup>	deg RMS, 1σ	0.05		
	Post processing accuracy (INS with u-blox ZD9P receiver) <sup>(1)</sup>	deg RMS, 1σ	0.1		
	<b>Pitch and Roll</b>		<b>Units</b>	<b>INS-DU-OEM</b>	
Range: Pitch, Roll	Deg	±90, ±180			
Angular Resolution	Deg	0.01			
Static Accuracy in whole Temperature Range	deg, 1σ	0.08			
Dynamic Accuracy <sup>(4)</sup>	deg RMS, 1σ	0.05			
Post processing accuracy <sup>(1)</sup>	deg RMS, 1σ	0.03			
<b>Gyroscopes</b>		<b>Units</b>	<b>INS-DU-OEM</b>		
<b>IMU</b>	Type	Industrial-grade			
	Measurement range	deg/sec	±2000		
	Bias in-run stability (RMS, Allan Variance)	deg/hr, 1σ	2		
	Bias instability after INS initialization (RMS)	deg/hr	10		
	Bias instability over temperature range (RMS)	deg/hr, 1σ	72		
	Angular Random Walk	deg/√hr, 1σ	0.38		
	<b>Accelerometers</b>		<b>Units</b>	<b>INS-DU-OEM</b>	
	Type	Tactical-grade			
	Measurement range	g	±8 g	±15 g	±40 g
	Bias in-run stability (RMS, Allan Variance)	mg, 1σ	0.01	0.03	0.05
Bias instability over temperature range (RMS)	mg, 1σ	0.7	1.1	1.5	
Bias one-year repeatability	mg, 1σ	1.5	2.0	2.5	
Velocity Random Walk	m/s/√hr, 1σ	0.02	0.045	0.06	
<b>Magnetometers</b>		<b>Units</b>	<b>INS-DU-OEM</b>		
Measurement Rate	Gauss	±8.0			
Bias in-run stability (Allan Variance)	μGauss, 1σ	8			
Power Spectral Density	μGauss/√Hz, 1σ	15			
SF Accuracy	% 1σ	0.05			
<b>Pressure</b>		<b>Units</b>	<b>INS-DU-OEM</b>		
Measurement Rate	hPa	300 – 1100			
Bias in-run stability (RMS, Allan Variance)	Pa	2			
Noise Density	Pa/√Hz	0.8			
<b>Environment</b>		<b>Units</b>	<b>INS-DU-OEM</b>		
<b>Electrical and Physical</b>	Operating temperature	deg C	-40 to +85		
	Storage temperature	deg C	-50 to +90		
	MTBF	hours	55,500		
	<b>Electrical</b>		<b>Units</b>	<b>INS-DU-OEM</b>	
	Supply voltage	V DC	9 - 34		
	Power consumption	Watts	5 (6 with data logger)		
	Output Interface (options)	-	RS-232 or RS-422, CAN Ethernet (optional)		
	Output data format	-	Binary, NMEA 0183 ASCII		
	<b>Physical</b>		<b>Units</b>	<b>INS-DU-OEM</b>	
	Size <sup>(5)</sup>	mm	85.5 x 47.7 x 40		
Weight <sup>(5)</sup>	gram	174			

<sup>(1)</sup> RMS, incremental error growth from steady state accuracy. Post-processing results using third party software; <sup>(2)</sup> Under ideal conditions that include proper static alignment and in-field dynamic motions during loss of GNSS signal; <sup>(3)</sup> 2 meters base line between two GNSS antennas; <sup>(4)</sup> dynamic accuracy may depend on type of motion; <sup>(5)</sup> Weight and size are PN dependent. Customers should obtain the most recent 2D/3D files before designing any interface hardware.

Receiver Options Available	Units	Septentrio mosaic-H	u-blox ZED-F9P
Available For	-	INS-DU-OEM (optional)	INS-DU-OEM (default)
Number of GNSS Antennas	-	Dual	Dual
GNSS Constellations	-	GPS L1C/A, L1C, L1PY, L2C, L2P, L5; GLONASS L1CA, L2CA, L2P, L3 CDMA; Beidou B1I, B1C, B2a, B2I, B3; Galileo E1, E5a, E5b, E5 AltBoc, E6; QZSS L1C/A, L1C, L2C, L5, L6; Navic L5; L-band	GPS L1C/A L2C, GLONASS L1OF L2OF, Galileo E1B/C E5b, BeiDou B1I B2I, QZSS L1C/A L2C
GNSS Corrections	-	WAAS; EGNOS; MSAS; GAGAN; SBAS L1, L5; DGPS; RTK	WAAS; EGNOS; MSAS; GAGAN; SBAS L1C/A; DGPS; RTK
Channel Configuration <sup>(1)</sup>	-	448	184
GNSS Data Rate <sup>(1)</sup>	Hz	100 (max)	10, 20 <sup>(2)</sup>
RTK Corrections	-	RTCM 2, RTCM 3	RTCM 3
Velocity Accuracy	m/s	0.03	0.05
Initialization Time	s	<45 (cold start), <20 (hot start)	<30 (cold start), <10 (hot start)
Time Accuracy (clock drift) <sup>(3)</sup>	Nano sec	20	30

<sup>(1)</sup> tracks up to 60 L1/L2 satellites; <sup>(2)</sup> If tracking GPS only; <sup>(3)</sup> time accuracy does not include biases due to RF or antenna delay

**INS-DU-OEM mechanical interface drawing (standard configuration)**

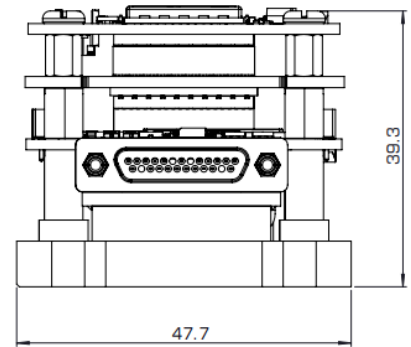
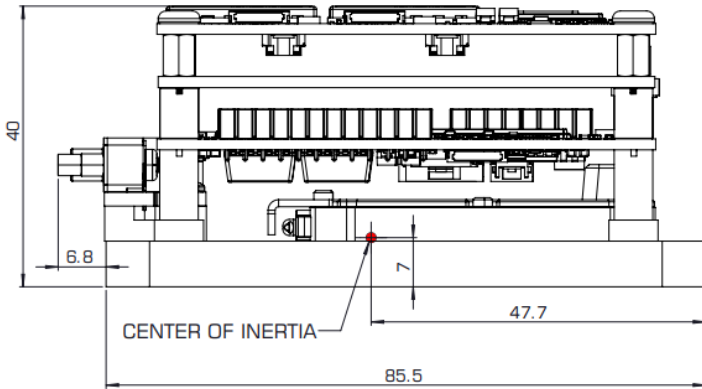

Device side: 25-pin connector  
MDSM-25PE-Z10-VR17

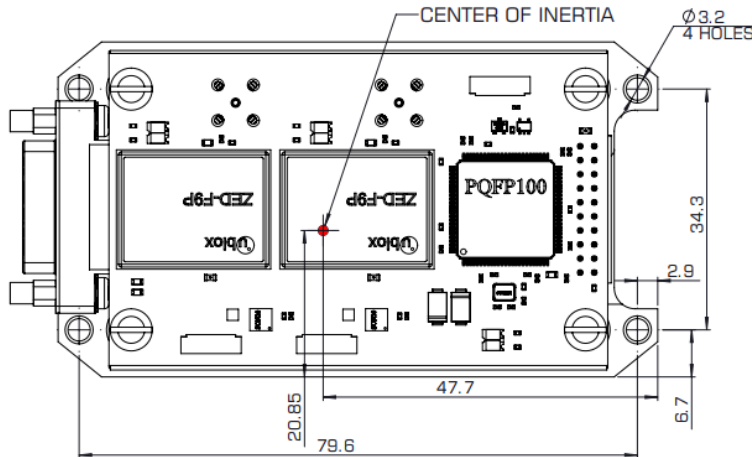

**Notes:**

1. All dimensions are in millimeters.
2. All dimensions within this drawing are subject to change without notice.
3. Weight and size are PN dependent. Customers should obtain the most recent 2D/3D files before designing any interface hardware.
4. Please contact Inertial Labs, Inc. if you need the INS unit to be delivered in a custom configuration with customized connector and output data.

**Product Code Structure:**

Model	Gyroscope	Accel	Calibration	Connector	Encoder	Stand Alone Magnetic Compass	Datalogger	GNSS receiver	Version	Interface
INS-DU-OEM	G2000	A8	TMGA	C4	E (option)	SAMC	S64 (default)	ZD9P	VD9	1
		A15		C6						2
		A40		C8						4
										5
										11
										22
										124
										145
										245

Example: INS-DU-OEM-G450-A15-TMGA-C6E-S64-ZD9P-VD9.1

**Product code details:**

- INS-DU-OEM: Low Cost Ublox Based GPS-Aided Inertial Navigation System Utilizing MiniAHRS
- G2000: Gyroscopes measurement range =  $\pm 2000$  deg/sec
- A8: Accelerometers measurement range =  $\pm 8$  g -> recommended for applications with low level of operational vibrations
- A15: Accelerometers measurement range  $\pm 15$  g -> recommended for applications with medium level of operational vibrations
- A40: Accelerometers measurement range  $\pm 40$  g -> recommended for high dynamic applications or/and with high level of vibration
- TMGA: Magnetometers, Gyroscopes and Accelerometers
- C4: Aluminum Base Plate - 26 pin header and ribbon cable (20021121-00026T4LF by Amphenol)
- C6: Aluminum Base Plate - 14 pin screw-lock connector (M80-5401442 by Harwin)
- C8: Aluminum Base Plate - 25-pin micro D-SUB connector with screw lock (MDSM-25PE-Z10-VR17 by ITT Cannon)
- E: Encoder support
- SAMC: Supports external Stand-Alone Magnetic Compass (optional; only supports interfaces .124)
- S8: 8GB embedded Data Logger (optional)
- S64: 64GB embedded Data Logger (optional)
- ZD9P: u-blox ZED-F9P dual antenna GNSS receiver
- DMH: Septentrio mosaic-H dual antenna GNSS receiver
- VD9: GPS L1/L2, GLO L1/L2, BDS B1/B2, GAL E1/E5, QZSS L1/L5, SBAS, RTK, Dual GNSS Heading, GNSS measurements, GNSS positions (Dual Antenna u-blox ZED-F9P Receiver only)
- VD91: GPS L1/L2, GLO L1/L2, GALILEO E1/E5b, BEIDOU B1/B2/B3, QZSS L1/L5, SBAS, RTK, Dual Antenna Heading, GNSS measurements, GNSS positions (Dual Antenna Septentrio Mosaic-H Receiver only)
- VX.1: RS-232 interface
- VX.2: RS-422 interface
- VX.4: CAN interface
- VX.5: Ethernet interface
- VX.11: two RS-232 interfaces
- VX.22: two RS-422 interfaces
- VX.124: RS-232, RS-422 and CAN interfaces
- VX.145: RS-232, CAN and Ethernet interfaces (with optional Encoder support)
- VX.245: RS-422, CAN and Ethernet interfaces (without Encoder support)