



**INS-DM-FI**

# FOG IMU-BASED AHRS AND INERTIAL NAVIGATION SYSTEM



The **Inertial Labs GPS-Aided Inertial Navigation System INS-DM-FI** is the newest Inertial Navigation System (INS) developed by Inertial Labs using Tactical-grade Fiber Optic Gyroscopes technology. The INS-DM-FI is the result of over 20 years of our experience in developing and supplying INS solutions to land, marine and aerial platforms around the world.

This system, the INS-DM-FI, is an IP68 rated version of an all-new generation of super ruggedized, shielded from the EMC/EMI, fully integrated, combined INS + AHRS + MRU + FOG IMU-based Attitude & Heading Reference System (AHRS) + optional embedded Air Data Computer (ADC) high-performance strapdown system. It determines position, velocity, vertical and horizontal displacements, and absolute orientation (Heading, Pitch and Roll) for any device on which it is mounted. Horizontal and Vertical Position, Velocity and Orientation are determined with high accuracy for both motionless and dynamic applications.



The Inertial Labs **INS-DM-FI** contains Inertial Measurement Units (IMU) utilizing Tactical-grade Fiber Optic Gyroscopes and MEMS accelerometers. The **INS-DM-FI** also utilizes embedded multi constellation (GPS, GLONASS, GALILEO, QZSS and BEIDOU) GNSS receivers like NovAtel OEM7 series, u-blox F9 or Septentrio mosaic-H series. The design of the **INS-DM-FI** also includes an optional embedded Air Data Computer (ADC), supported by two barometers, and the ability to support an external Stand-Alone Magnetic Compass (SAMC).

The **INS-DM-FI** contains Inertial Labs latest version of the on-board sensor fusion filter, state of the art navigation and guidance algorithms, and calibration software.

### **KEY FEATURES, BENEFITS & FUNCTIONALITY**



- Commercially exportable GPS-Aided Inertial Navigation System (ECCN 7A994)
- 3-in-1 strapdown system: IMU + AHRS + INS
- Fiber Optic Gyroscopes (FOG) & MEMS accelerometers Inertial Measurement Unit (IMU)
- NovAtel OEM7, u-blox ZED-F9P, or Septentrio mosaic-H High Precision GNSS receiver
- Embedded Anti-Jamming and Spoofing mitigation features
- L1/L2/L5 GPS, GLONASS, GALILEO, BEIDOU, QZSS, IRNSS
- SP, SBAS, DGPS, RTK and PPP for real time operation
- Advanced, extendable, embedded Kalman Filter based sensor fusion algorithms
- State-of-the-art algorithms for Land, Aerospace and Maritime applications
- Full temperature calibration of all sensing elements according MIL-STD-810 standard
- MIL-STD-461 standard based EMC, EMI, and ERD protection
- MIL-STD-1275 compliance
- Environmentally sealed (IP68)
- Aiding data: Wind sensor, Air Speed Sensor, Doppler shift from locator (for long-term GPS denied), External position and External Heading
- External Air Data Computer (ADC) and Stand Alone Magnetic Compass (SAMC)

<b>GENERAL</b>	<b>OPTIONAL INPUT SIGNALS</b>	
	<ul style="list-style-type: none"> <li>External Magnetometer, External Air Data Computer (ADC), Wind sensor, Air Speed Sensor, Doppler shift from locator (for long-term GPS denied), External position and External Heading aiding data</li> </ul>	
	<b>OUTPUT DATA</b>	
	<ul style="list-style-type: none"> <li>IMU data: Accelerations, Angular rates, Magnetic field;</li> <li>AHRS data: Heading, Pitch &amp; Roll</li> <li>MRU data: Heave, Surge, Sway</li> <li>INS data: Positions, Velocity, Delta Theta and Delta Velocity, GNSS data, Time</li> <li>External Air Data Computer data: Static Pressure (calibrated), Dynamic Pressure (calibrated), Baro-Corrected Pressure Altitude, Pressure Altitude, Calibrated Airspeed, True Airspeed, Mach-Number, Static Pressure Over Total Pressure, True Angle of Attack, Rate of Climb</li> </ul>	
	<b>ELECTRICAL AND MECHANICAL</b>	
	Update rate	1 ... 200 Hz (INS, MRU & AHRS data); up to 2000 Hz (IMU data)
	Start-up time	<1 sec
	Interface	RS-232 / RS-422 / CAN / Ethernet
	Input power protection	MIL-STD-1275 (optional)
	Input power	9 to 36 V DC (27 ± 10 for MIL-STD-1275 protection)
	Output data	Binary, NMEA 0183 ASCII characters
	1 PPS level	3.3 V DC TTL / 5 V DC TTL / differential
	EMC/EMI	MIL-STD-461F
	Type of Sealing	IP68
	MTBF	100000 hours
	Dimensions	160 x 149 x 96 mm
	Weight	1345 grams
	<b>ENVIRONMENT</b>	
	Operational Temperature	-40 to +80C
	Storage Temperature	-50 to +85C
Humidity	Up to 95%	
Sand, Dust, Water, Shock, Vibration	MIL-STD-810G	
Altitude	up to 15,000 m (50,000 ft)	
Acoustic noise	185 dB max	

<b>INERTIAL MEASUREMENT UNIT (IMU)</b>	<b>GYROSCOPES</b>		
	Technology		Closed-loop FOG
	Measurement range	deg/sec	±490
	Bandwidth (-3dB)	Hz	200
	Data update rate	Hz	400 (1000 is optional)
	Bias repeatability (over temperature range)	deg/hr	0.5
	SF accuracy (over temperature range)	ppm	100
	Noise. Angular Random Walk (ARW)	deg/vhr	0.025 (typical)
	Non-linearity	ppm	50
	<b>ACCELEROMETERS</b>		
	Technology		MEMS
	Measurement range	g	±8      ±40
	Bandwidth (-3dB)	Hz	260      260
	Data update rate	Hz	400 (1000 is optional)      400 (1000 is optional)
	Bias in-run stability (RMS, Allan Variance)	mg	0.005      0.02
	Bias repeatability (over temperature range)	mg	0.5      1.2
	SF accuracy (over temperature range)	ppm	150      500
	Noise. Velocity Random Walk (VRW)	m/sec/vhr	0.015 (typical)      0.045 (typical)
	Non-linearity	ppm	150      150

<b>EXTERNAL STAND-ALONE MAGNETIC COMPASS (SAMC)</b>	Output signals	Heading, Pitch, Roll; Quaternion; PPS Time; Accelerations; Angular rates; Magnetic field; Delta Theta & Delta Velocity	
	Update rate	Hz	1 ... 2000 (user settable)
	Start-up time	sec	< 1
	<b>HEADING</b>		
	Range	deg	0 to 360
	Angular Resolution	deg	0.01
	Static Accuracy in Temperature Range	deg, 1 $\sigma$	0.5
	Dynamic Accuracy	deg RMS, 1 $\sigma$	1.0
	<b>PITCH AND ROLL</b>		
	Range: Pitch, Roll	deg	$\pm 90, \pm 180$
	Angular Resolution	deg	0.01
	Static Accuracy in Temperature Range	deg, 1 $\sigma$	0.05
	Dynamic Accuracy	deg RMS, 1 $\sigma$	0.08

<b>EXTERNAL AIR DATA COMPUTER (ADC)</b>	Aiding Data Input		External GNSS receiver data, ambient air data
	Pressure Sensor Measurement Range	mbar	$\pm 25; \pm 600$
	Static Pressure (calibrated)	hPa, % FS	300 to 1100 hPa, from -2000 ft to 30000 ft, Accuracy: $\pm 0.1\%$ FSS
	Dynamic Pressure (calibrated)	hPa, % FS	0.15 to 25 hPa / 10 to 124 KCAS (600 KCAS is optional), Accuracy: $\pm 0.25\%$ FSS
	Baro-Corrected Pressure Altitude	meters	-500 to 9000 meters; Accuracy: 1
	Pressure Altitude	meters	-500 to 9000 meters; Accuracy: 1
	Calibrated Airspeed	meters/sec	5 to 64 meters/sec (310 meters/sec is optional); Accuracy: 0.5
	True Airspeed	meters/sec	5 to 64 meters/sec (310 meters/sec is optional); Accuracy: 0.5
	Mach-Number	M	0.01 to 0.2 M, Accuracy: 0.001 M
	Static Pressure Over Total Pressure		0.97 to 1, Resolution 0.000001
	True Angle of Attack	deg	-50 to 50 deg; Accuracy $\pm 0.25$
	Rate of Climb	meters/sec	$\pm 515$ meters/sec; Accuracy 0.05
	Air Density	kg/m <sup>3</sup>	0.3 to 1.6 kg/m <sup>3</sup> ; Accuracy 0.002
	Outside Air Temperature (OAT)	deg C	-40 to +85 degC; Resolution 0.01
	Wind Speed	meters/sec	$\pm 200$ meters/sec; Accuracy: 0.1
	Operating Altitude	meters	Up to 10000 meters / 32800 ft
	Humidity	%	<95
	Operating temperature	deg C	-40 to +85
	Storage temperature	deg C	-50 to +90
	Type of Sealing		IP-67
	Sand, Dust, Humidity, Shock, Vibration		MIL-STD-810G
	MTBF (GM)	hours	100,000
	Supply voltage	V DC	5-30
	Power consumption	Watts	Range: 0.26-0.63, Typical: 0.35
	Output Interface	-	RS-232 or RS-422
	Output data format	-	Binary
Nominal Size <sup>(7)</sup>	mm	73.4 x 55 x 29.5	
Weight <sup>(7)</sup>	gram	130	

<b>GNSS Receiver Options</b>	 <b>NovAtel OEM7720</b>	 <b>u-blox ZED-F9P</b>	 <b>Septentrio mosaic-H</b>
<b>Number of GNSS Antennas</b>	Dual	Dual	Dual
<b>GNSS constellations</b>	GPS L1 C/A, L1C, L2C, L2P, L5; GLONASS L1 C/A, L2 C/A, L2P, L3, L5; BeiDou B1I, B1C, B2I, B2a, B3I; Galileo E1, E5 AltBOC, E5a, E5b, E6; Navic (IRNSS) L5; QZSS L1 C/A, L1C, L2C, L5, L6; L-Band	GPS L1C/A L2C, GLONASS L1OF L2OF, Galileo E1B/C E5b, BeiDou B1I B2I, QZSS L1C/A L2C	GPS L1C/A, L1C, L1PY, L2C, L2P, L5; GLONASS L1CA, L2CA, L2P, L3 CDMA; Beidou B1I, B1C, B2a, B2I, B3; Galileo E1, E5a, E5b, E5 AltBoc, E6; QZSS L1C/A, L1C, L2C, L5, L6; Navic L5; L-band
<b>GNSS corrections</b>	WAAS; EGNOS; MSAS; GAGAN; SBAS L1, L5; DGPS; RTK; PPP TerraStar	WAAS; EGNOS; MSAS; GAGAN; SBAS; DGPS; RTK	WAAS; EGNOS; MSAS; GAGAN; SBAS; DGPS; RTK
<b>Channel configuration</b> <sup>(1)</sup>	555 Channels	184 Channels	448 Channels
<b>GNSS data rate</b> <sup>(1)</sup>	5 Hz / 20 Hz / 100 Hz	10, 20 Hz <sup>(2)</sup>	100 Hz (max)
<b>RTK corrections</b>	RTCM 2, RTCM 3	RTCM 3	RTCM 2, RTCM 3
<b>Velocity accuracy, RMS</b>	0.03 m/sec	0.05 m/sec	0.03 m/sec
<b>Initialization time</b>	<39 (cold start), <20 (hot start)	<30 (cold start), <10 (hot start)	<45 (cold start); <20 (hot start)
<b>Time accuracy (clock drift)</b> <sup>(3)</sup>	20 nano sec	30 nano sec	20 nano sec

<sup>(1)</sup> tracks up to 60 L1/L2 satellites; <sup>(2)</sup> if tracking GPS Only; <sup>(3)</sup> time accuracy does not include biases due to RF or antenna delay

<b>INS-DM-FI MAIN SPECIFICATION</b>	<b>NAVIGATION</b>	
	Horizontal position accuracy (SP)	1.2 m
	Horizontal position accuracy (SBAS) <sup>(1)</sup>	0.6 m
	Horizontal position accuracy (DGPS)	0.4 m
	Horizontal position accuracy (PPP TerraStar-C PRO) <sup>(2)</sup>	0.025 m
	Horizontal position accuracy (RTK)	0.01 m
	Vertical position accuracy (RTK)	0.02 m
	Velocity accuracy (OEM7720, Mosaic H), RMS	0.03 m/sec
	Velocity accuracy (uBlox F9P), RMS	0.05 m/sec
	Horizontal Position accuracy (free inertial, land vehicles)	0.1% DT
	Horizontal Position accuracy (free inertial, aerial)	<2 NMPPH
	<b>HEADING</b>	
	Range	0 to 360 deg
	Angular Resolution	0.01 deg
	Static & Dynamic Accuracy <sup>(4)</sup> (Dual antenna, 1 meter baseline)	0.15 deg
	Static & Dynamic Accuracy <sup>(4)</sup> (Dual antenna, 2 meters baseline)	0.08 deg
	Dynamic Accuracy <sup>(4)</sup> (Single antenna)	0.15 deg
	Post processing accuracy <sup>(3)</sup>	0.01 deg
	Free inertial (without GNSS and Magnetometer)	<0.5 deg
	With External Stand-Alone Magnetic Compass (after calibration)	1 deg
	<b>PITCH &amp; ROLL</b>	
	Range	±90, ±180 deg
	Angular Resolution	0.01 deg
	Static Accuracy	0.01 deg
	Dynamic Accuracy	0.01 deg
	Post processing accuracy <sup>(3)</sup>	0.005 deg
	<b>HEAVE, SURGE, SWAY</b>	
	Measurement range	±300 meters
	Resolution	0.01 meters
	Real time accuracy, RMS	5 % / 0.05 meters
Post Processing (delayed) accuracy, RMS	2 % / 0.02 meters	

**Notes:** <sup>(1)</sup> GPS only; <sup>(2)</sup> For Novatel OEM7720 GNSS receiver only. Requires a subscription to a TerraStar data service; <sup>(3)</sup> RMS, incremental error growth from steady state accuracy. Post-processing results using third party software; <sup>(4)</sup> dynamic accuracy may depend on type of motion

## INS-DM-FI Mechanical Interfaces Description

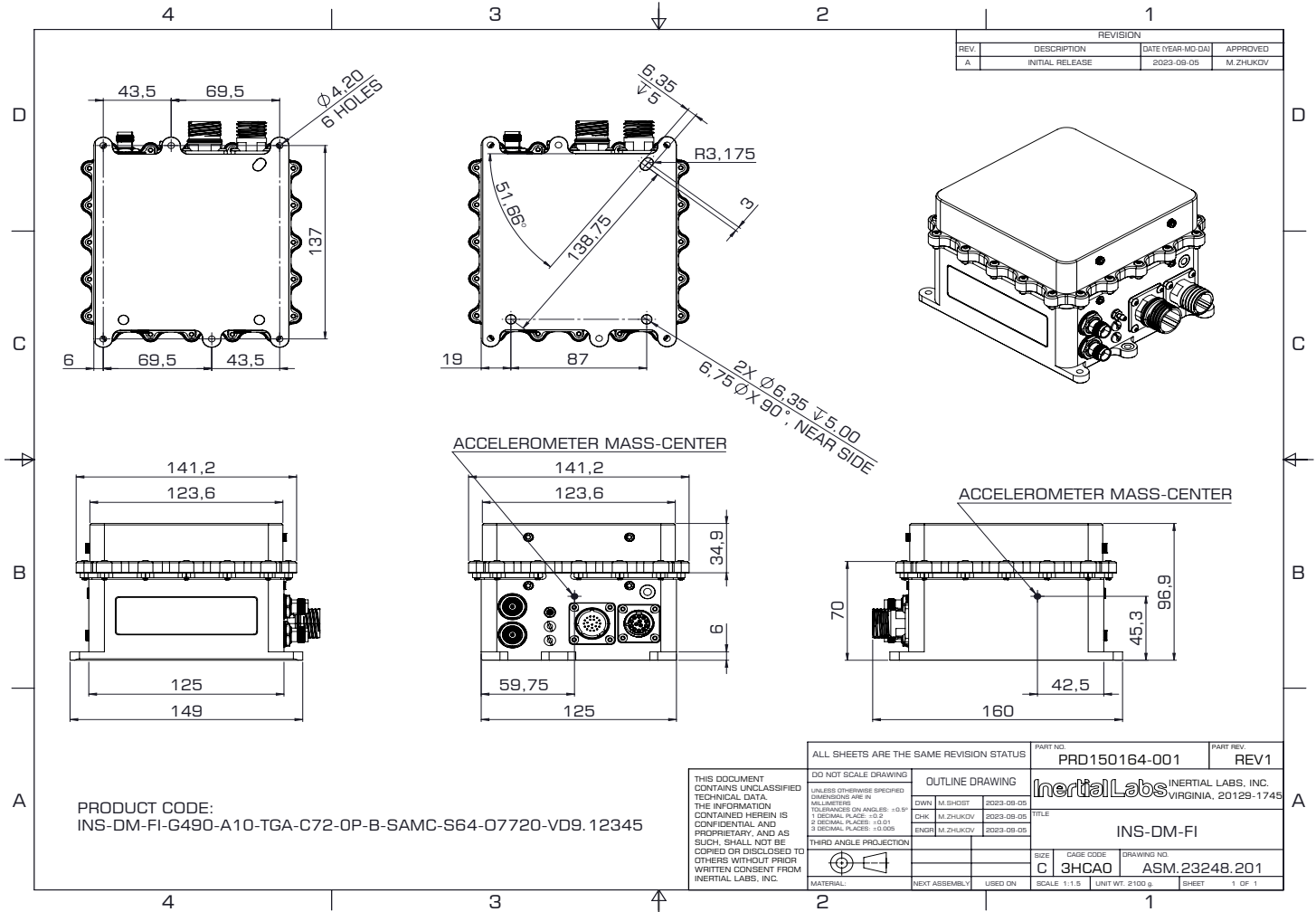

## Product Code Structure

Model	IMU	Gyro	Acc	Calibration	Connector	Encoder	Color	External Compass	Data Logger	GNSS receiver	Version	Interface
INS-DM	FI	G490	A8 A40	TGA	C71 C72 C73	E	B	SAMC	S64	ZD9P O7720 DMH	VD9 VD93	12345

Example: INS-DM-FI-G490-A40-TGA-C71E-B-SAMC-S64-ZD9P-VD9.12345

### Product code details:

- INS-DM: Dual Antenna GPS-Aided Inertial Navigation System
- FI: FOG IMU-FI-200T
- G490: Gyroscopes measurement range = ±490 deg/sec
- A8: Accelerometers measurement range ±8g
- A40: Accelerometers measurement range ±40g
- TGA: Calibration of IMU (Gyroscopes and Accelerometers) in operational temperature range
- C71: two connectors (22 – main; 13 – auxiliary)
- C72: C71 with MIL-STD-1275 protection
- C73: MIL-STD-1275 protection, enclosure with asymmetrical alignment mounting holes
- E: Encoder support
- B: Black Color of enclosure (default)
- SAMC: External Stand-Alone Magnetic Compass (optional)
- S64: 64GB embedded Data Logger (optional)
- ZD9P: u-blox ZED-F9P dual antenna GNSS receiver
- O7720: NovAtel OEM7720 dual antenna GNSS receiver
- DMH: Septentrio mosaic-H dual antenna GNSS receiver
- VD9: GPS L1/L2, GLONASS L1/L2, BEIDOU B1/B2, GALILEO E1/E5, QZSS L1/L5, DGPS, RTK, Dual antenna Heading, GNSS measurements, GNSS positions (Dual Antenna GNSS Receiver only)
- VD93: GPS+GAL+BDS+QZSS, L1/L2/L5/E1/E5a/E5b/AltBOC/B1/B2/B2a/B2b, NavIC L5, SBAS, L1/L5 Dual Antenna Activation, RTK+PPP+Single Point+DGPS PNT, ALIGN Heading, 20 Hz Data Output Rate, Base Station Corrections + Measurements, GRIT Interference Mitigation and Spoofing Detection Includes GLIDE & RAIM
- .12345: RS-232, RS-422, RS-485 (for stand-alone magnetic compass only), CAN, Ethernet

### Optional External Air Data Computer (ADC)

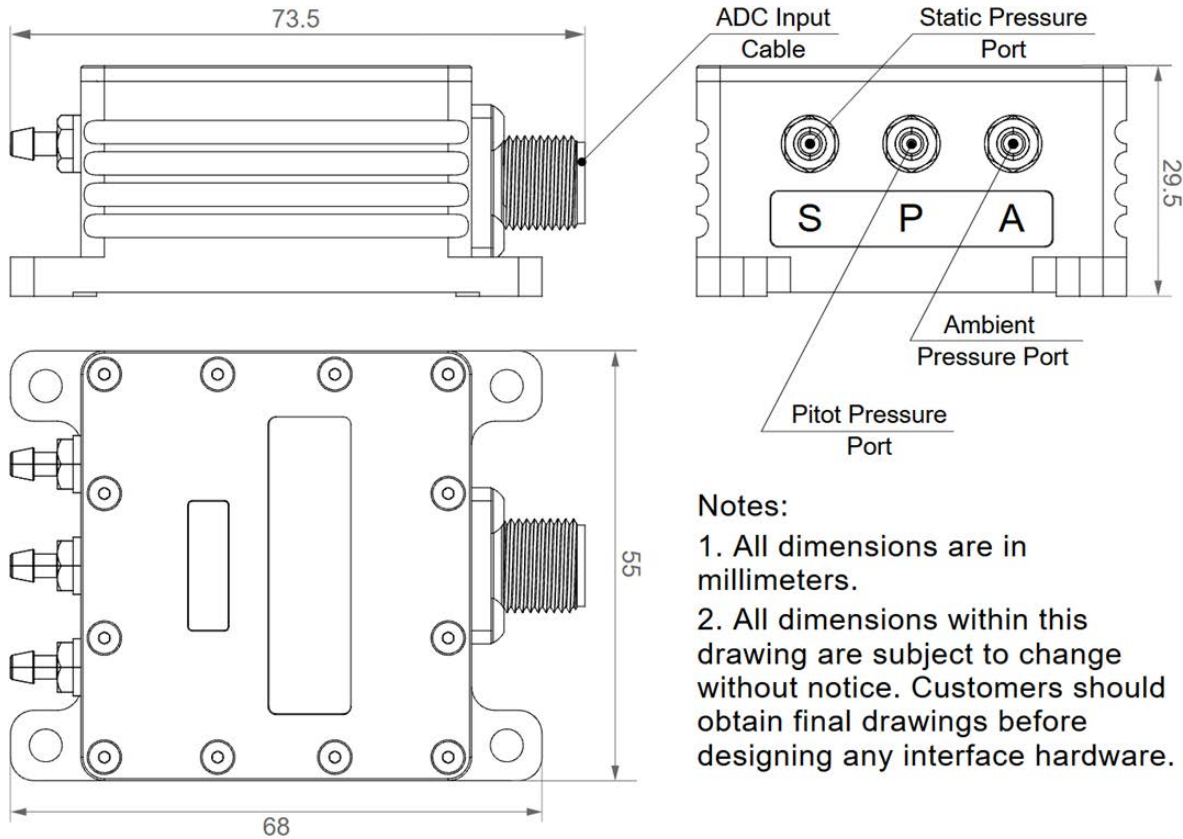

- Notes:**
1. All dimensions are in millimeters.
  2. All dimensions within this drawing are subject to change without notice. Customers should obtain final drawings before designing any interface hardware.

### Optional External Stand-Alone Magnetic Compass (SAMC)

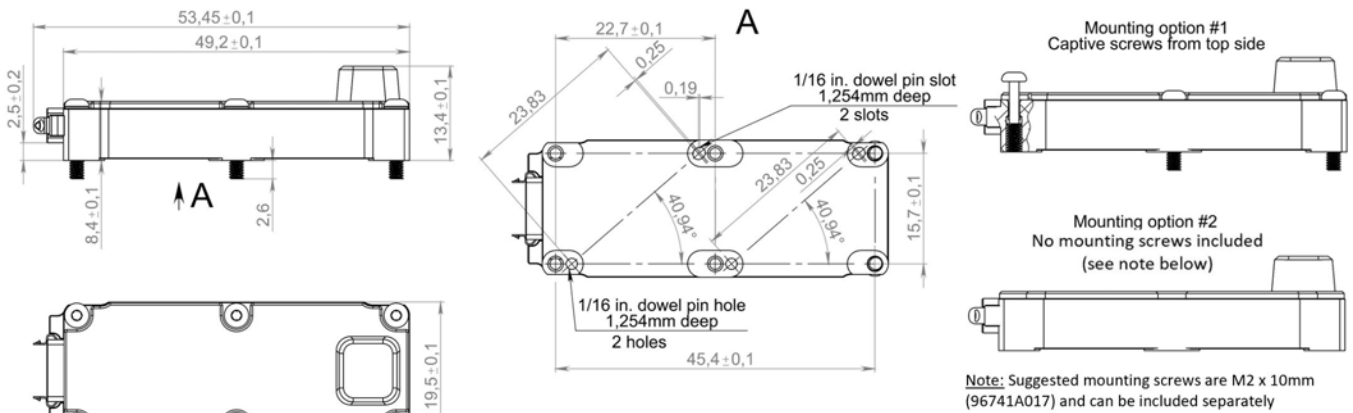

Mating option #2 - screw-lock connector - G125-2241096F1

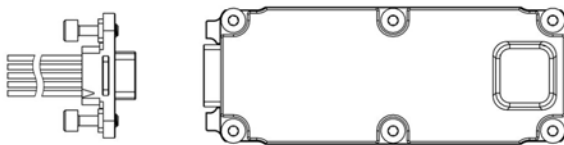

ADDITIONAL PARTS			
ITEM NO.	PART NUMBER	DESCRIPTION	QTY.
1	SSBA-M2-10-A2	M2 x 10mm Captive Screws	6
2	96741A017	M2 x 10mm	6
3	97325A101	Brass Dowel Pin, 1/16" Diameter, 1/4" Long	2
4	G125-FC11005F1-0150L	Screw-lock connector with cable	1